

Part No.: **SOL-5100XWC**

**SPECIFICATION FOR APPROVAL**

Customer

Specification

SOL-5100XWC

Deliver Date

Basic parameters

See the specification

Special Requirements

NO

Issued

Checked

Approved

Customer Approved Signatures

Customer Feedback:

Your advices are our source of progress !

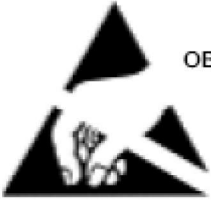
Part No.: **SOL-5100XWC****ATTENTION**

OBSERVE PRECAUTIONS  
FOR HANDLING  
ELECTROSTATIC  
DISCHARGE  
SENSITIVE  
DEVICES

**1. Features:**

- Emitting Color: White
- High bright output
- Low power consumption
- High reliability and long life
- RoHS compliant

**2. Descriptions:**

- Dice material: InGaN
- Emitting Color: Super Bright White
- Device Outline:  $\phi 5\text{mm}$  Round Type/5mm
- Lens Type: Water Clear

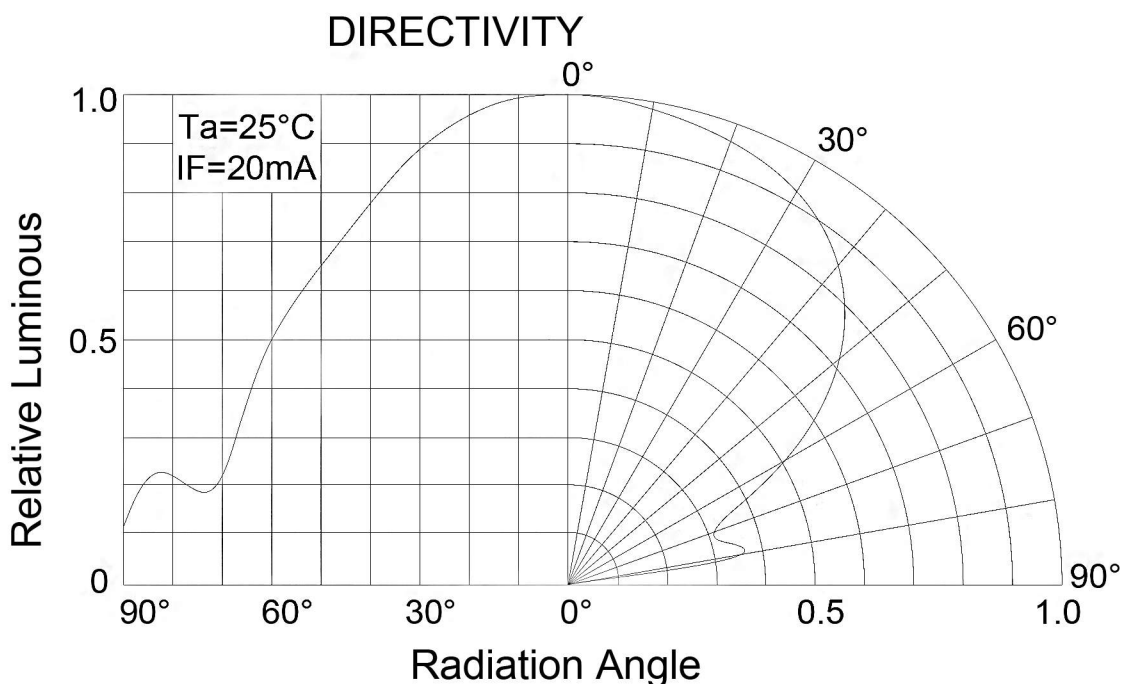
**3. Directivity:**

Part No.: **SOL-5100XWC**

4. Outline Dimensions:

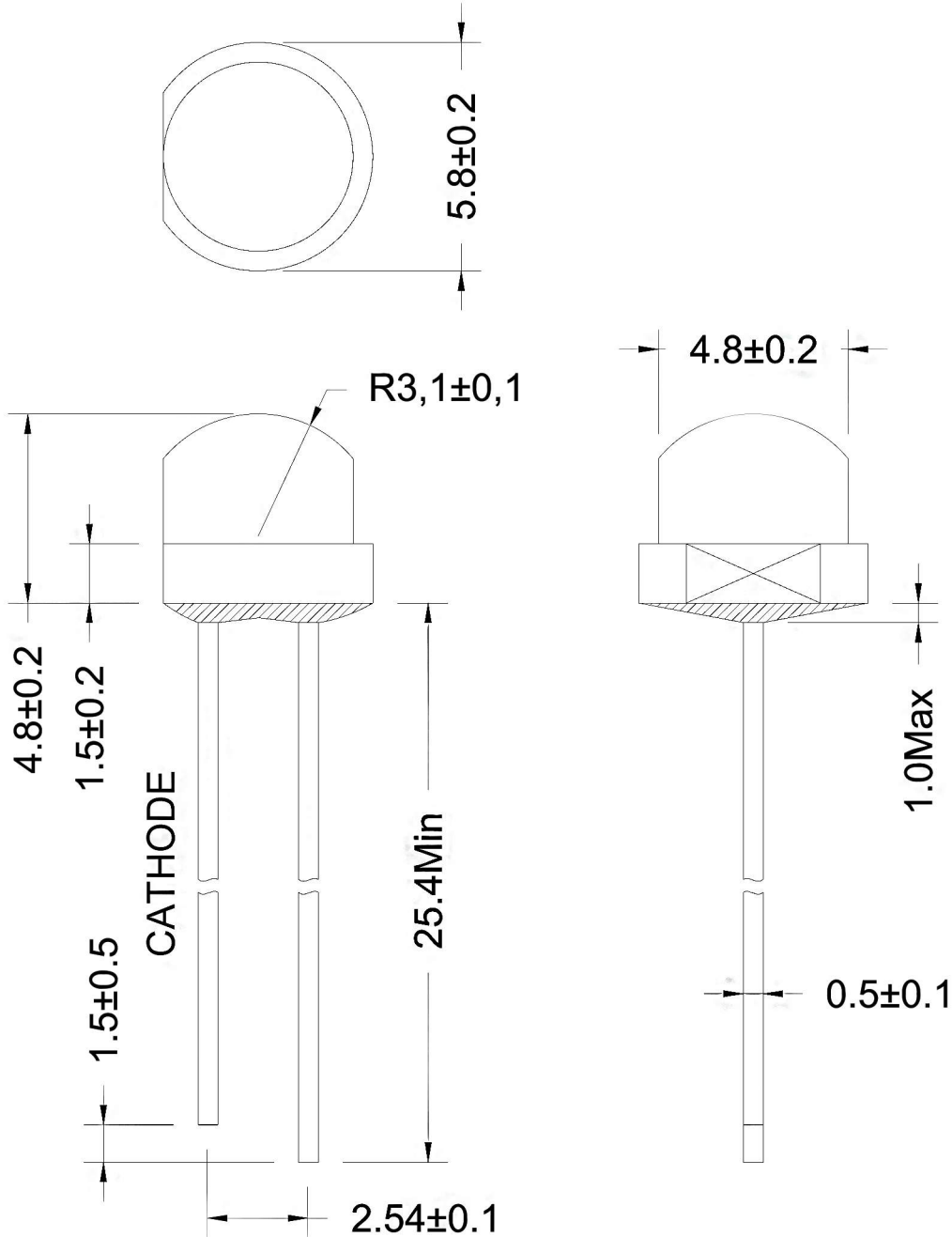

**NOTE:**

- All dimensions are millimeters : mm
- Tolerance is  $\pm 0.25$  mm unless otherwise noted

**Part No.:** **SOL-5100XWC**

5. Absolute maximum ratings ( $T_a = 25^\circ\text{C}$ )

Parameter	Symbol	Test Condition	Value		Unit
			Min.	Max.	
Reverse Voltage	$V_R$	$I_R = 30 \mu A$	5	--	V
Forward Current	$I_F$	----	----	25	mA
Power Dissipation	$P_d$	----	----	90	mW
Pulse Current	$I_{peak}$	Duty=0.1mS, 1kHz	----	100	mA
Operating Temperature	$T_{opr}$	----	-40	+85	$^\circ\text{C}$
Storage Temperature	$T_{str}$	----	-40	+100	$^\circ\text{C}$

6. Electrical and optical characteristics ( $T_a = 25^\circ\text{C}$ )

Parameter	Symbol	Test Condition	Value			Unit
			Min.	Typ.	Max.	
Forward Voltage	$V_F$	$I_F = 20\text{mA}$		3.2	3.6	V
Reverse Current	$I_R$	$V_R = 5\text{V}$	----	----	30	$\mu A$
Luminous Intensity	$I_V$	$I_F = 20\text{mA}$	----	1500	----	mcd
Viewing Angle	$2\theta 1/2$	$I_F = 20\text{mA}$	----	120	----	Deg.

**Notes:** Tolerance:  $V_F$ :  $\pm 0.10\text{V}$ ,  $I_V$ :  $\pm 15\%$ , other:  $\pm 5\%$

7. Luminous Intensity Bins Chart ( $T_a = 25^\circ\text{C}$ )

Bin	T	U	V	W
Min	1000	1500	2000	3000
Max	1500	2000	3000	4000

**Notes:** Rank error:  $I_V$ :  $\pm 15\%$

**Part No. : SOL-5100XWC**

8. Chromaticity Coordinates Ranks (IF=20mA Ta=25°C)

Color coordinate error: ±0.01

Code	axis	Parameter				Code	axis	Parameter			
Wa1	X	0.2217	0.2301	0.2389	0.2309	Wa2	X	0.2309	0.2389	0.2476	0.2399
	Y	0.2114	0.2271	0.2209	0.2065		Y	0.2065	0.2209	0.2147	0.2018
Wa3	X	0.2399	0.2476	0.2567	0.2496	Wa4	X	0.2301	0.2386	0.2469	0.2389
	Y	0.2018	0.2147	0.2083	0.1967		Y	0.2271	0.2428	0.2352	0.2209
Wa5	X	0.2389	0.2469	0.2553	0.2476	Wa6	X	0.2476	0.2553	0.2636	0.2567
	Y	0.2209	0.2352	0.2276	0.2147		Y	0.2147	0.2276	0.2201	0.2083
Wa7	X	0.2387	0.2491	0.2571	0.2469	Wa8	X	0.2469	0.2571	0.2651	0.2553
	Y	0.2427	0.2619	0.2531	0.2352		Y	0.2352	0.2531	0.2443	0.2276
Wa9	X	0.2553	0.2651	0.2731	0.2637	Wa10	X	0.2491	0.2596	0.2672	0.2571
	Y	0.2276	0.2443	0.2355	0.2200		Y	0.2619	0.2811	0.2711	0.2531
Wa11	X	0.2571	0.2672	0.2748	0.2651	Wa12	X	0.2651	0.2748	0.2824	0.2731
	Y	0.2531	0.2711	0.2610	0.2443		Y	0.2443	0.2610	0.2510	0.2355
Wb1	X	0.2596	0.2693	0.2759	0.2672	Wb2	X	0.2672	0.2759	0.2825	0.2748
	Y	0.2811	0.2974	0.2857	0.2711		Y	0.2711	0.2857	0.2740	0.2610
Wb3	X	0.2748	0.2825	0.2890	0.2824	Wb4	X	0.2693	0.2791	0.2846	0.2759
	Y	0.2610	0.2740	0.2623	0.2510		Y	0.2974	0.3138	0.3004	0.2857
Wb5	X	0.2759	0.2846	0.2901	0.2825	Wb6	X	0.2825	0.2901	0.2957	0.2890
	Y	0.2857	0.3004	0.2870	0.2740		Y	0.2740	0.2870	0.2737	0.2623
Wb7	X	0.2791	0.2899	0.2940	0.2846	Wb8	X	0.2846	0.2940	0.2981	0.2901
	Y	0.3138	0.3268	0.3138	0.3004		Y	0.3004	0.3138	0.3007	0.2870
Wb9	X	0.2901	0.2981	0.3032	0.2957	Wb10	X	0.2899	0.3008	0.3035	0.2940
	Y	0.2870	0.3007	0.2845	0.2737		Y	0.3268	0.3398	0.3272	0.3138
Wb11	X	0.2940	0.3035	0.3062	0.2981	Wb12	X	0.2981	0.3062	0.3103	0.3032
	Y	0.3138	0.3272	0.3144	0.3007		Y	0.3007	0.3144	0.2947	0.2845
Wc1	X	0.3008	0.3197	0.3205	0.3028	Wc2	X	0.3028	0.3205	0.3214	0.3048
	Y	0.3398	0.3589	0.3481	0.3304		Y	0.3304	0.3481	0.3352	0.3209
Wc3	X	0.3048	0.3214	0.3221	0.3068	Wc4	X	0.3068	0.3221	0.3229	0.3103
	Y	0.3209	0.3352	0.3261	0.3113		Y	0.3113	0.3261	0.3130	0.2947
Wc5	X	0.3197	0.3381	0.3376	0.3206	Wc6	X	0.3206	0.3376	0.3371	0.3214
	Y	0.3589	0.3740	0.3616	0.3461		Y	0.3461	0.3616	0.3493	0.3352
Wc7	X	0.3214	0.3371	0.3366	0.3222	Wc8	X	0.3222	0.3366	0.3361	0.3229
	Y	0.3352	0.3493	0.3369	0.3243		Y	0.3243	0.3369	0.3241	0.3130
Wd1	X	0.3381	0.3475	0.3463	0.3376	Wd2	X	0.3376	0.3463	0.3452	0.3371
	Y	0.3740	0.3817	0.3687	0.3616		Y	0.3616	0.3687	0.3558	0.3493
Wd3	X	0.3371	0.3452	0.3440	0.3366	Wd4	X	0.3366	0.3440	0.3427	0.3361
	Y	0.3493	0.3558	0.3428	0.3369		Y	0.3369	0.3428	0.3284	0.3241



Part No.: **SOL-5100XWC**

Wd5	X	0.3475	0.3569	0.3551	0.3463	Wd6	X	0.3463	0.3551	0.3533	0.3452
	Y	0.3817	0.3894	0.3760	0.3687		Y	0.3687	0.3760	0.3624	0.3558
Wd7	X	0.3452	0.3533	0.3515	0.3440	Wd8	X	0.3440	0.3515	0.3494	0.3427
	Y	0.3558	0.3624	0.3487	0.3428		Y	0.3428	0.3487	0.3328	0.3284

9. CIE 1931 Chromaticity diagram/CIE1931 (IF=20mA Ta=25°C)

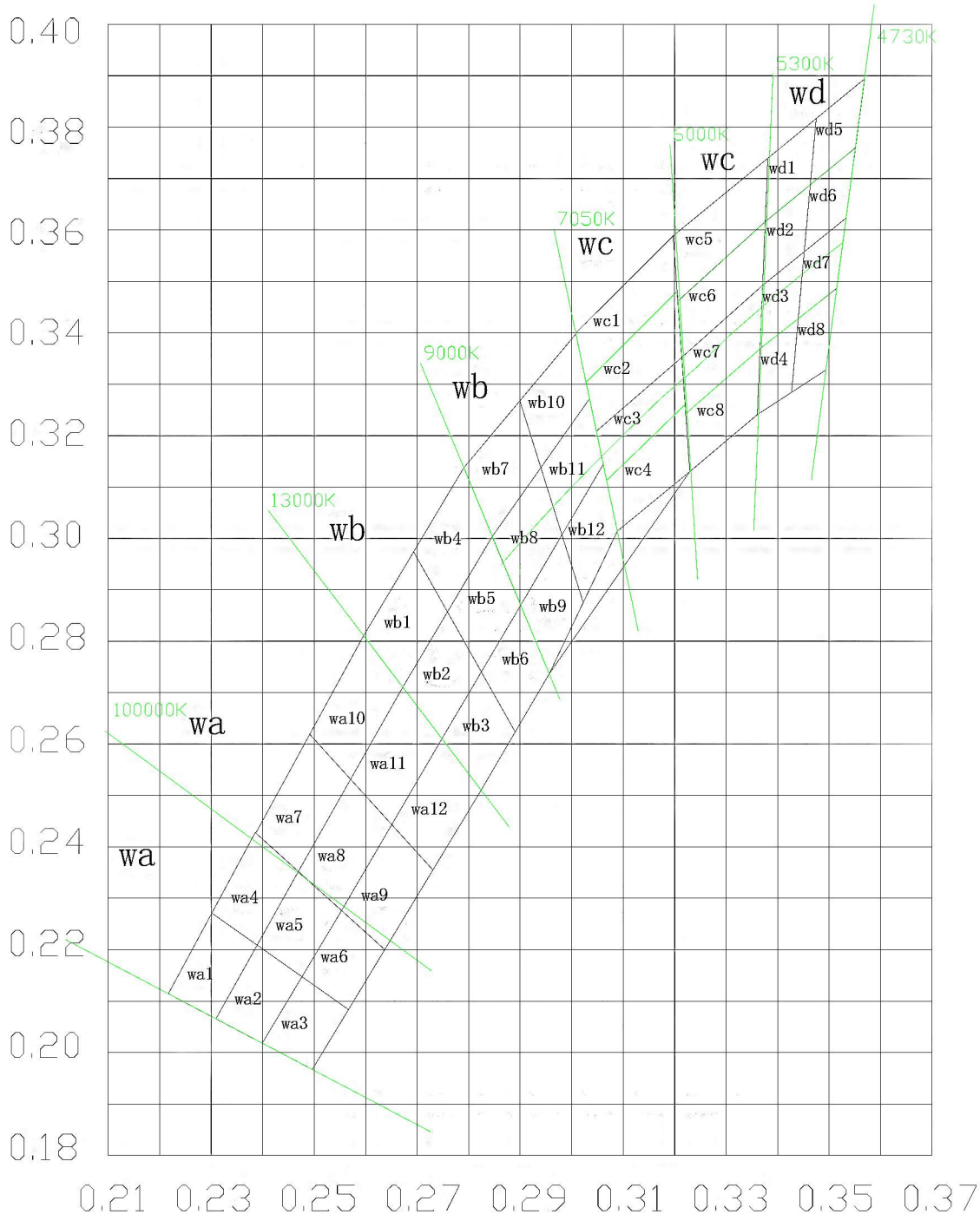

**Part No.:** **SOL-5100XWC**

10. Typical electrical/optical characteristic curves:

Fig.1 Forward Current Vs. Forward Voltage

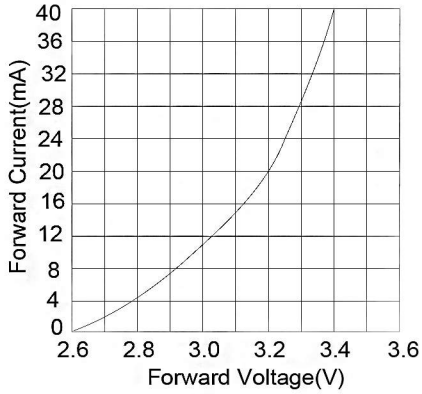

Fig.2 Relative Brightness Vs. Forward Voltage

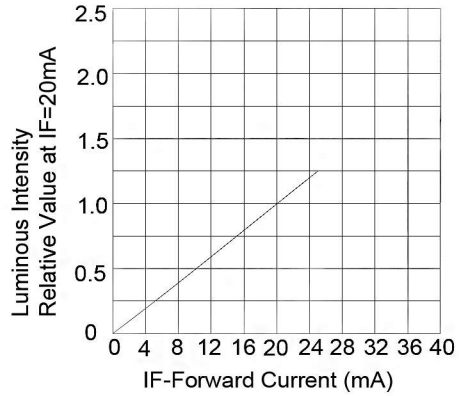

Fig.3 Forward Current Vs. Ambient temperature

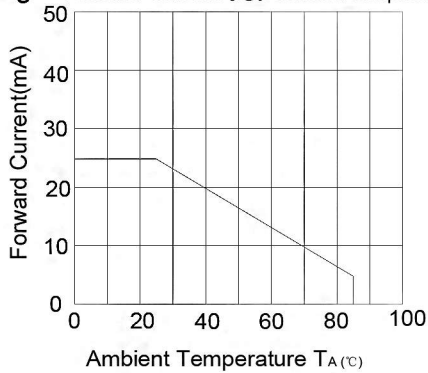

Fig.4 Relative Brightness Vs. Ambient temperature

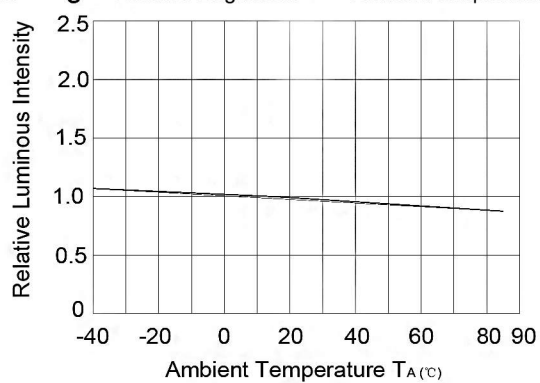
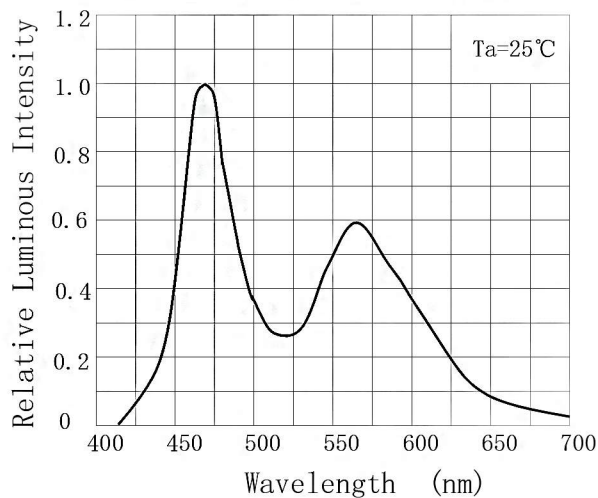

Fig.5 Relative brightness Vs Wavelength



**Part No.:** **SOL-5100XWC**

## 11. Label Form Specification

	
P/N:	_____
Rank:	____ / ____ / ____
Qty:	_____ pcs QC: _____
Date:	_____
Lot No:	_____
	<a href="http://www.SOL-Lightengine.com">www.SOL-Lightengine.com</a>

P/N: Customer's Production Number

QTY: Packing Quantity

Ranks: Iv / Vf / WD

Iv: Iv Rank; Vf: Vf Rank; WD: Color Group

QC: Quality Control chapter

Date: mm / dd / yy

mm: Month; dd: Date; yy: Year;

Lot No: Production batch Number

## 12. Lead Forming

1. Any lead forming or bending must be done before soldering.

2. When forming leads, there must be a minimum of 2mm clearance between the base of the LED lens and the lead bend.



**Part No. : SOL-5100XWC**

- 3. Avoid bending the leads at the same point more than once.
- 4. During assembly onto PCB, the lead pitch of the LED must match the pitch of the mounting holes on the PCB during component placement.

**13. Soldering Condition**

Careful attention should be paid during soldering. When soldering, leave more than 2mm from solder joint to case, and soldering beyond the base of the tie bar is recommended.

Avoiding applying any stress to the lead frame while the LEDs are at high temperature particularly when soldering.

**Recommended soldering conditions :**

Hand Soldering		DIP Soldering	
Temp.at tip of iron	300°C Max.(30WMax.)	Preheat temp.	100°C Max. (60 sec Max.)
Soldering time	3 sec Max.	Bath temp.	260°C Max
Distance	2mm Min.(From solder joint to case)	Bath time.	3 sec Max.
		Distance	2mm Min

**Part No.:** **SOL-5100XWC**

## 14. Cleaning

1. Do not clean LEDs with water, Alcohol are recommended solvents for cleaning. When using other solvents, it should be confirmed beforehand whether the solvents will dissolve the resin or not.
2. LEDs may be damaged by ultrasonic-washed. Before cleaning, a pre-test should be done to confirm whether any damage to the LEDs will occur.

## 15. Storage

1. Environmental temperature:  $-40^{\circ}\text{C}$ --- $100^{\circ}\text{C}$ , Recommended:  $-20^{\circ}\text{C}$ --- $50^{\circ}\text{C}$
2. Environmental humidity: 30%---70%, Recommended: 40%---60%

## 16. Static Electricity

1. Static Electricity or power surge will damage the LED.

It is recommended that a wrist band or an anti-electrostatic glove be used when handling the LEDs.

2. All production machinery and test instruments must be electrically grounded.

**Part No.:** **SOL-5100XWC**

3. Maintain a humidity level of 50% or higher in production areas.

4. Use anti-static packaging for transport and storage.

## 17. Notes

1. This datasheet will be update regularly, if there comes out any changes, pls confirmed by the latest datasheet.

2. When using this product, please observe the absolute maximum ratings and the instructions for using outlined in these specification sheets. SUNPU assumes no responsibility for any damage resulting from use of the product which does not comply with the absolute maximum ratings and the instructions included in these specification sheets.